

Synapsis NX



Scalable workstations for (Chart-) Radar, ECDIS and Conning



SYNOPSIS NX Workstations

Synopsis NX workstations are based on an innovative and advanced “next generation” system architecture – this is what the “NX” stands for. Using only a small number of standardized hardware components, the NX architecture significantly improves flexibility and reliability and simplifies installation and maintenance.

BENEFITS AT A GLANCE

- (Chart-) radar, ECDIS, and conning with clear user interfaces and intuitive workflows
- Advanced functions for consistent data, better situational awareness and easier operation (known from INS, now offered as a standard with Synopsis NX workstations)
- Integrated redundancies, safety and efficiency through “any function at any place”
- Fewer and standardized components for better reliability and scalability
- Smart software simplifies system configuration and service
- Streamlined sensor collection for flexibility and reduced cabling
- Easy installation, low installation cost

With the Synopsis NX series, Raytheon Anschutz also presents a new generation of navigational applications for (chart-) radar, ECDIS and conning. The new software was designed with continuous user participation in order to create applications with an unparalleled intuitiveness in use.

Advanced functions (formerly only found on complete “Integrated Navigation Systems”) have now become a standard for each workstation, even in case of a stand-alone installation.

These functions ensure a consistent use of qualified data and consistent alert handling throughout the system. Navigators receive a validated picture of the prevalent situation, are released from superfluous workload, and are supported in right decision making. This means a significant contribution to safer navigation and more efficient watchkeeping.





SYNOPSIS NX WORKSTATIONS OFFER MORE THAN JUST ECDIS OR RADAR

Synopsis NX Workstations can be easily configured according to customer’s individual requirements – from a stand-alone radar or ECDIS workstation up to a fully integrated multifunctional workstation.

The workstations are based on the Small Marine Computer (SMC). The SMC hosts a common software backbone called the Bridge Integration Platform (BIP), which is the heart of each workstation. Navigational applications are added on top and provide a harmonized interface to the user.

The BIP takes over central services of the system and ensures consistent use of data and consistent alert handling throughout the system. These smart functions are now available as a stan-

dard with any new Synopsis NX Workstation in order to support navigators and contribute to a better situational awareness:

- CCRS: sensor data is checked for integrity, validity and plausibility
- Corrupted / manipulated data is detected and excluded automatically
- Consistent data and target designations are used at any connected workstation
- Health monitoring takes place with automated switch-over
- Intelligent central alert management (CAM) reduces stress and directs attention to critical alerts

For more information about these functions, please visit our website: www.raytheon-anschuetz.com/synopsis

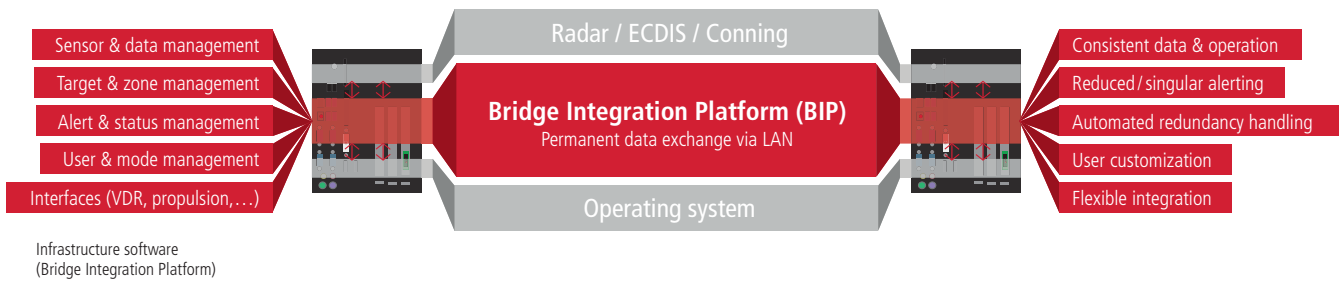

HUMAN-CENTERED SOFTWARE DESIGN

“Human error” – incorrect situational assessment, caused by poor or inconsistent presentation of data or confusing operation and subsequent incorrect decision-making – has been named in many investigations as a main reason for accidents in global shipping. In particular, in times of ongoing digitalization and integration aboard, the design of new navigational software should concentrate on “user needs” and the “human element”.

When designing this new generation of navigational software, Raytheon Anschutz adopted a new course of continuous user participation. The goal was to design intuitive and consistent user interfaces and operation concepts which meet or even exceed the expectations of the operators and support their common interaction patterns with regard to daily tasks and use cases.

The agile development process took more than 24 months and included various workshops with navigators and nautical experts. The process covered a detailed analysis of more than

300 tasks and use cases, insights from international research projects on bridge ergonomics and operations, and a phase of prototyping with selected users. From the start, the feedback valued the clarity of the new UI and the operation concept, the intuitiveness of use throughout the different tasks as well as supportive functions which provide assistance to the operator.

The new Synopsis NX is now launched, incorporating latest software technologies and an intuitive user interface based on customer feedback and user experience. In fact, it is the first navigation system featuring a user-defined interface design.

RADAR NX / CHART RADAR NX

Raytheon Anschutz replaced the current radar software with the next generation, Synapsis Radar NX. Consistent with the human centered software design, a team of experienced marine radar users, UI experts and skilled SW developers created a remarkably intuitive user interface requiring little or no training.

Optimized grouping of data and current settings allow a superior overview and instant determination of the situation and interpretation of the radar picture. The quick access bar makes the most often used operations and functions available at a fingertip, including touch operation.

The Synapsis Radar NX features an advanced tracker, which is derived from a high performance, commercial small target tracking application. Together with the lossless digital video distribution of the NautoScan NX radar transceivers this results in an optimized performance in tracking and anti-clutter processing.

Based on the LAN distribution, any transceiver data is routed with high flexibility to any workstation hosting the Radar NX software. Combining multiple radar transceivers via the optional radar video merging function provides a single, unobstructed radar video to the users which is also available as a merged radar video overly on ECDIS NX.



FEATURES AT A GLANCE

- Advanced tracker and raw video processing for high radar performance
- New and efficient UI based on Synapsis NX human centered design principles
- Little or no training needed, proved by users such as masters, pilots and trainers
- Support of user profiles; each user is able to store their favorite settings
- Support of radar video merging of multiple radar sensors and distribution to ECDIS (Option)
- Functions known from INS, e.g.: enhanced target management, integrated handling of sensor data, automatic selection of best data set, multi-user setting management
- Fully type approved according to IEC 622388 Ed. 2.0

Synapsis NX Chart Radar, night color

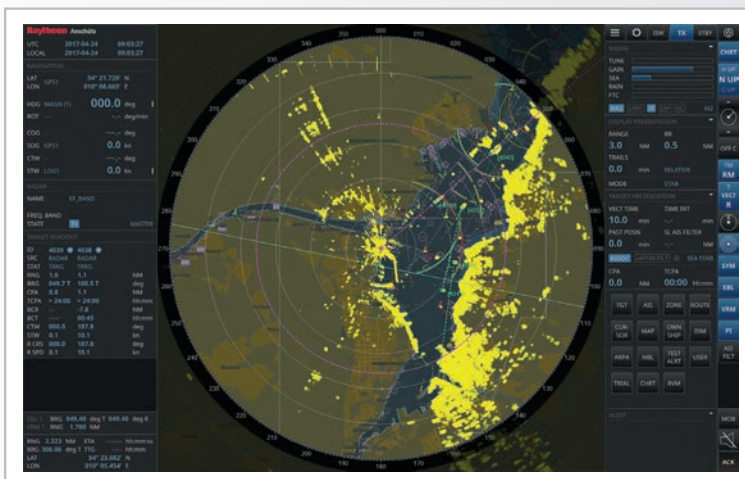

Synapsis NX Chart Radar, day color

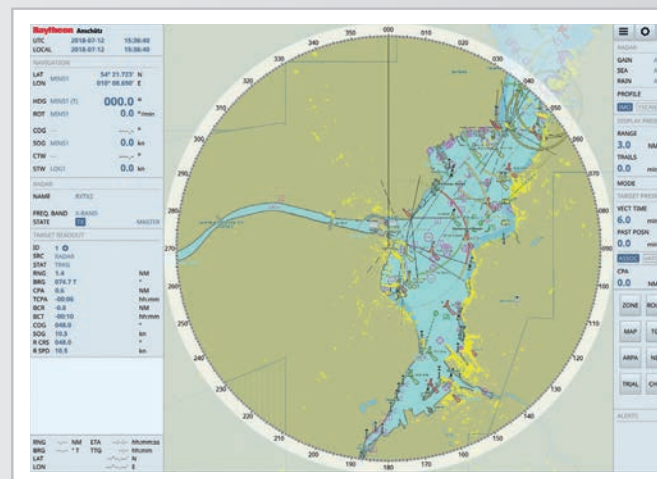



Left-hand side:
Indication only

Right-hand side:
Indication & operation

Navigation data, incl. source
and quality indication

Quick access bar with navigation tools
Function related menus

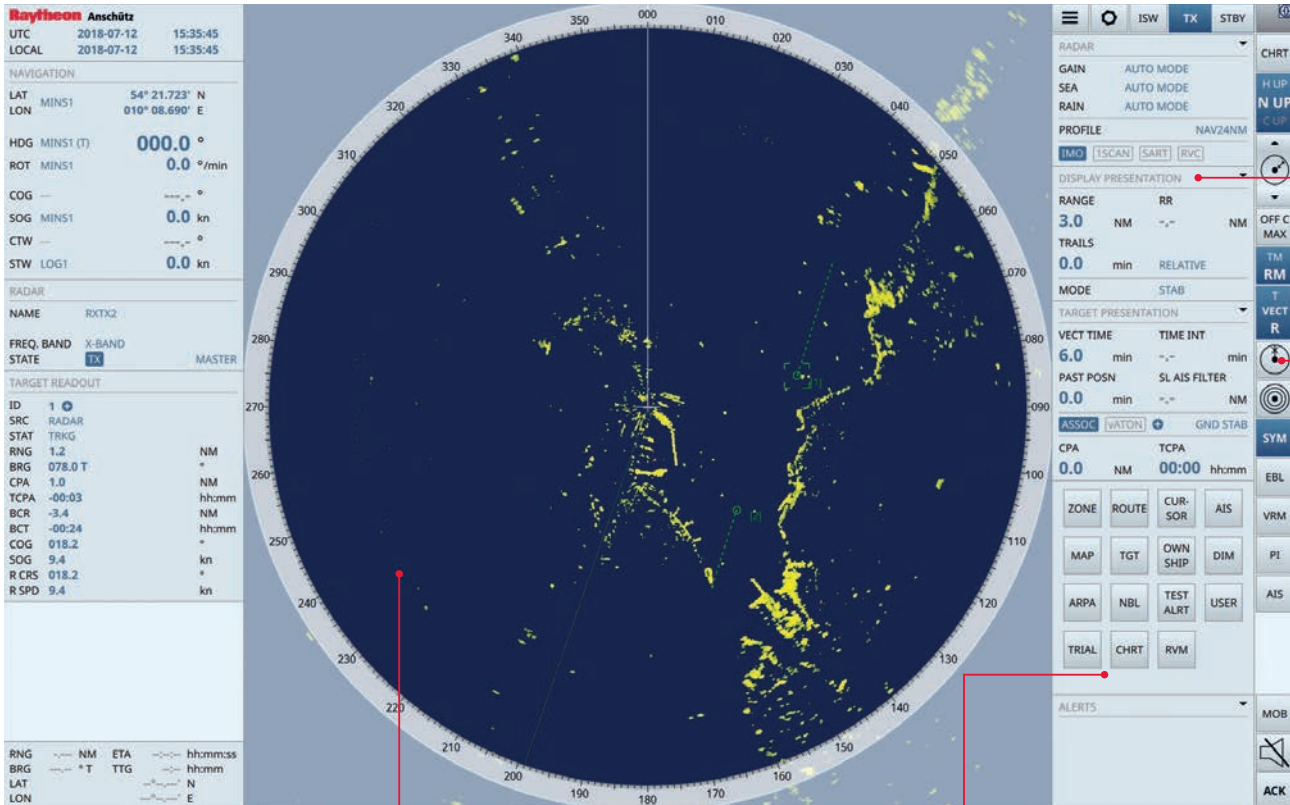

Target information
(system level)

Chart radar
function

Tile menu with
flat hierarchy

Drag and drop
navigation tools

Synopsis NX Radar offers advanced functions

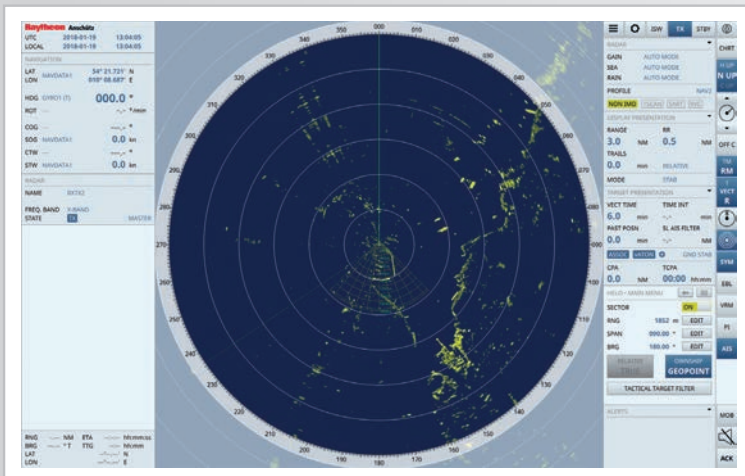

SYNOPSIS ECDIS NX

Raytheon Anschutz offers an advanced electronic chart display and information system (ECDIS) in a modern, state of the art design.

ECDIS NX was designed to effectively support the daily tasks and use cases of navigators. During route monitoring the navigator benefits from a display with maximum chart area.

Important operational functions are available at a single click, and indications can be fixed or retracted as needed, based on navigator preferences. User and task oriented profile settings support safety and usability.

Route planning, as a key feature, is now a wizard-guided process that further utilizes intuitive principles such as point to chart or drag and drop to set waypoints as well as a self-explanatory route manager and comprehensive voyage planning tools. Optional upgrades in functionality beyond IMO-requirements include highly precise track control Cat. C, digital radar video overlay including display of merged multi-radar video sources, tender tracking, and additional chart formats such as ARCS and BSB.

Being fully compliant to rules and regulations, having support of Admiralty Information Overlay (AIO by AVCS) and being prepared for S-100 charts make the Synopsis ECDIS NX the first choice for a modern, future proof bridge design. Crews will familiarize themselves quickly with the new user interface and the human-centered operation concept. This makes ECDIS NX also a perfect solution for retrofits.

All deliveries include access to the maker-specific online ECDIS training. A partner network of land-based training facilities is also available.

 **More information under:**
www.raytheon-anschuetz.com/eccistraining/

FEATURES AT A GLANCE

- Extremely intuitive use, context-sensitive help function
- Wide screen displays and retractable UI panels for maximized view of the charts
- Wizard based voyage planning, graphical editing of routes
- Speed and ETA calculation for each waypoint and leg in UTC or local time
- Editable look ahead zones for anti-collision, route monitoring and anti-grounding
- Extensive filtering tools to reduce unnecessary alarms
- High precision track control Cat. C with Anschutz autopilots
- Central chart management – charts and chart updates have to be loaded on one NX workstation only
- Central route management and route distribution - a route can be planned once and used at any ECDIS NX workstation
- Functions known from INS, e.g.: enhanced target management, integrated sensor data handling, automatic selection of best data set, multi-user setting management
- Support of Admiralty Information Overlay (AIO by AVCS, subscription required)
- Fully type approved according to IEC 61174 Ed. 4.0 and IHO Presentation Library S-52 Annex A Edition 4.0 incl. DNV GL certificates

Chart formats/ availability

- S 57/S 63 Encrypted ENC
- ARCS (option)
- DNC (option)
- BSB (option)
- Additional military chart formats on request

Synopsis ECDIS NX offers advanced route planning

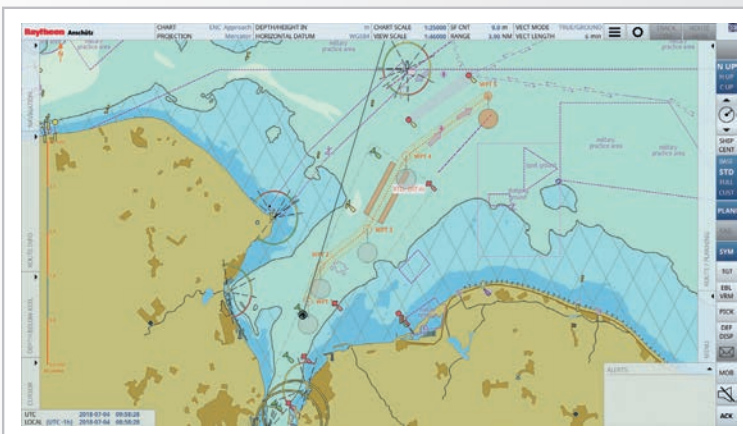

ECDIS NX with maximized chart window

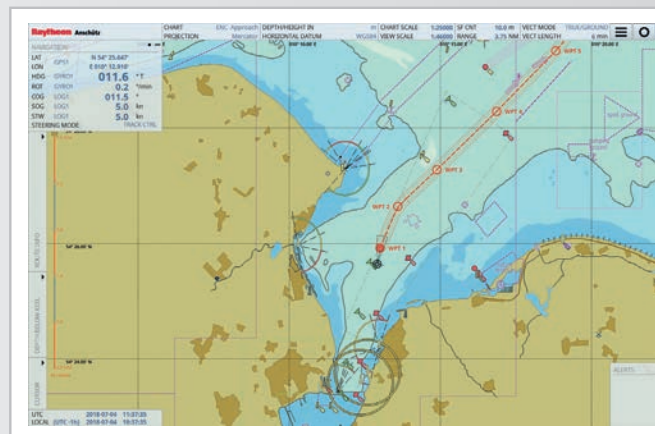



Left-hand side:
Indication only

Right-hand side:
Indication & operation

Individual retractable panels:

- fixation or
- ▲ retraction

Quick access bar
Function related menus

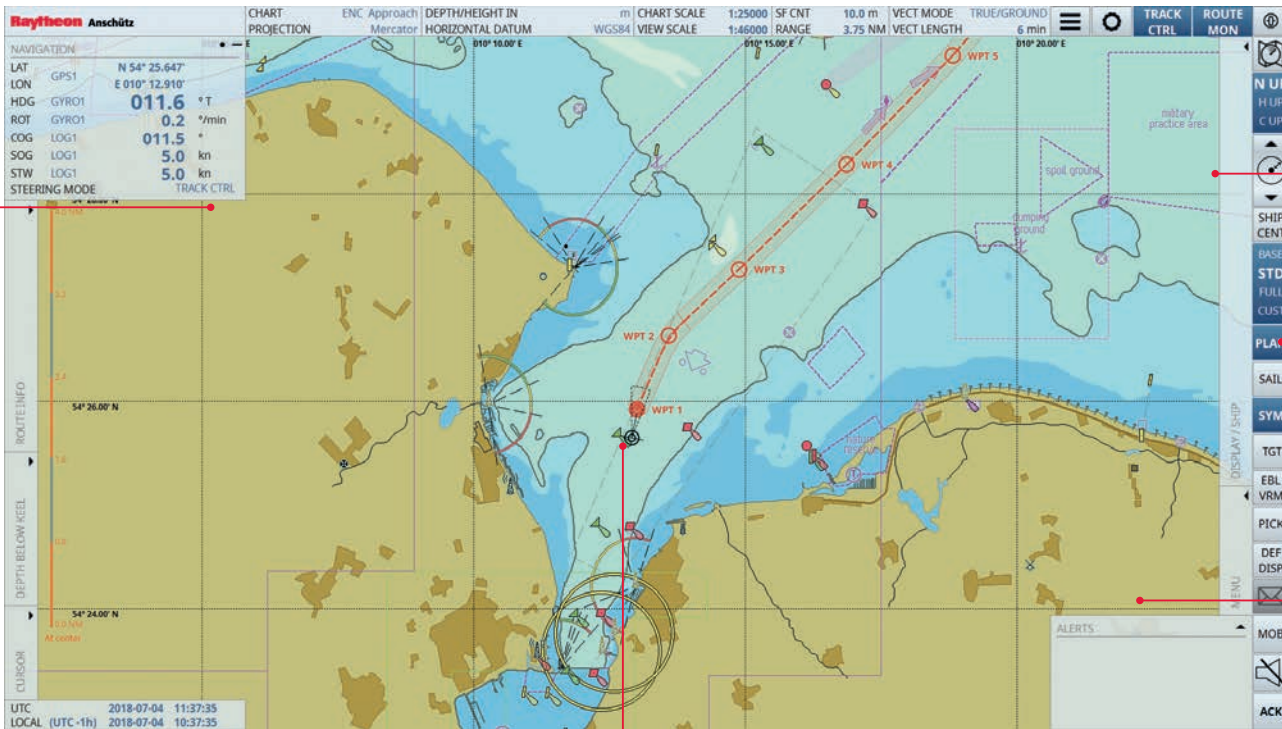

Customizable
by user profiles

Route planning
by drag and drop

Tile menu with
2 layers only

WANT TO LEARN MORE ABOUT THE NEW USER INTERFACES AND OPERATION CONCEPTS OF ECDIS NX AND RADAR NX?



Visit the website www.raytheon-anschuetz.com/nx-generation and find out details about the first user-defined navigation software in the market.

You can watch videos to experience modern MMI and the new intuitive operation of the ECDIS NX and Radar NX. You can also learn about the benefits of INS functionality, which is now made available with any Synopsis NX workstation.



SYNOPSIS CONNING NX

Synopsis Conning NX is the centralized data display for the ship's command. It makes all bridge navigation and machinery status data easily available at a glance.

The combination of different instruments and indications at a central display increases situational awareness, even in critical situations of maneuvering and docking. It provides the operator with efficient help in right decision making; Conning NX is a strong contributor to safety at sea.

As a standard, the Conning NX features different display modes for different maneuvering situations and for different types of equipment. These include a navigation data display page, a docking display page, a heading and rudder movement recording page, an instruments page, and a track control page. Conning NX also acts as the central HMI for INS functions such as sensor management, intelligent central alert monitoring and system health monitoring.

Conning NX is a versatile and extremely capable software. Besides the standard pages it allows an optional creation of individual display pages and even the implementation of additional functionality, such as the ability to control and actuate external hardware interfaces.

FEATURES AT A GLANCE

- Standard pages for various vessel types
- Additional situational awareness, easy to add to a system
- Not only a display: Conning allows operation of various functions (CCRS sensor selection, CAM centralized alert presentation)
- Approved to latest IMO standard for bridge alert management (MSC.302(87))
- Graphics are individually adapted to the specific type of equipment ("widgets")
- Different pre-configured pages for different maneuvering situations (e.g. navigation, docking, track)
- Flexible application design allows creation of individual graphics and pages (option)
- Central HMI for functions provided within an integrated navigation system (INS)

Synopsis Conning NX

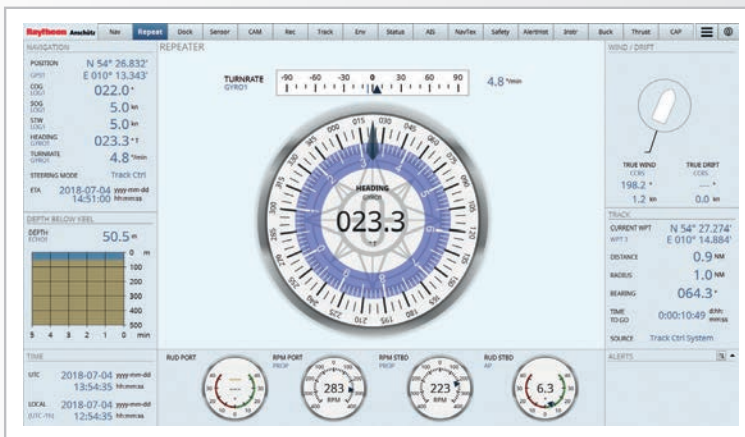

Docking page

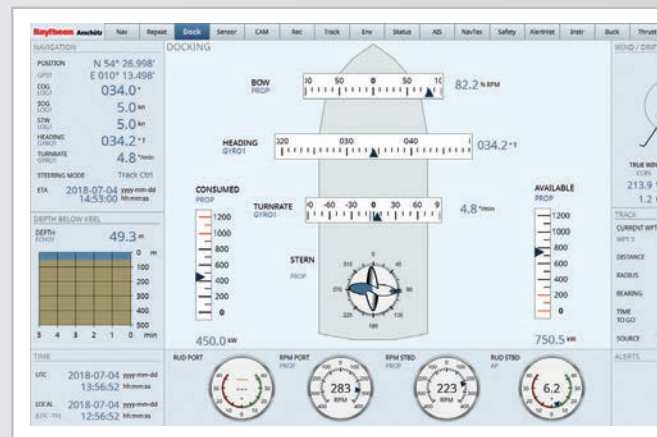



Conning NX application on 12" Synapsis Touch Panel

The new Synapsis Touch Panel (STP) is a smart multifunctional display.

Together with the Synapsis Touch Panels, Conning NX can provide the HMI for a centralized alert HMI (CAM-HMI) of the INS, on bridge level or as a bridge alert management system for DNV Class Notation NAUT OSV.

Furthermore, thanks to its modular and user-oriented structure, Conning NX can integrate various analog and digital displays within customized display pages. Customer-specific, switchable elements can be created for dedicated functional pages and to actuate the respective hardware interfaces.



Central display of system health status

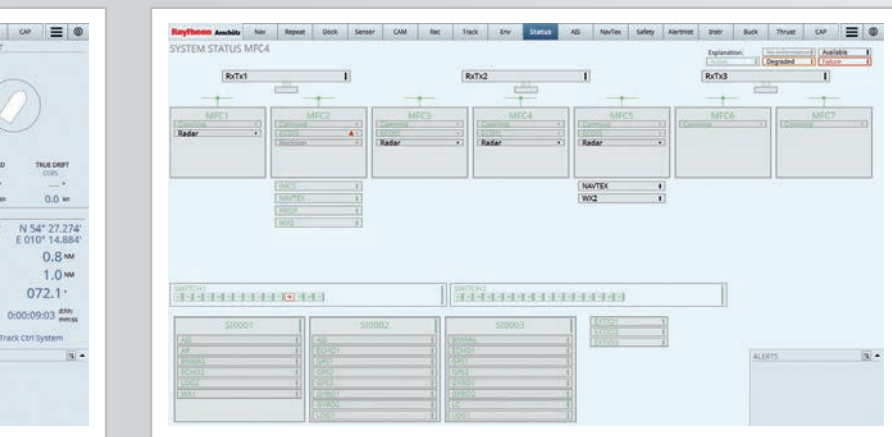

SMART SYSTEM ARCHITECTURE

The new NX architecture reduces complexity and offers smart scalability, redundancy, flexibility, and resistance to failures.

All sensor data is enabled to LAN, via the NautoPlex data collectors. Sensor data, as well as the raw radar video, is distributed to the workstations via LAN. The workstations are based on the Small Marine Computers. The function of a dedicated workstation is defined by software.

Customers can choose from (chart-) radar, ECDIS, or conning software, either stand-alone or in any combination. The function of a workstation can also be redefined at any time or expanded during the lifetime of the ship – for example to adapt to new rules, regulations, or operational requirements.

Benefits:

- Redundant network
- Software-defined multifunctional workstations
 - are based on standardized PCs (SMCs) and software (ease of logistics and service)
 - offer integrated redundancy
 - can easily be redefined or expanded
- Integration of sensors via LAN, digital raw radar video
- High flexibility, transparency, and upgradability in systems configuration
- Lower installation cost and lower lifecycle cost
- Separation of hardware (e.g. in a rack) is possible – reducing cost for commissioning, installation and servicing

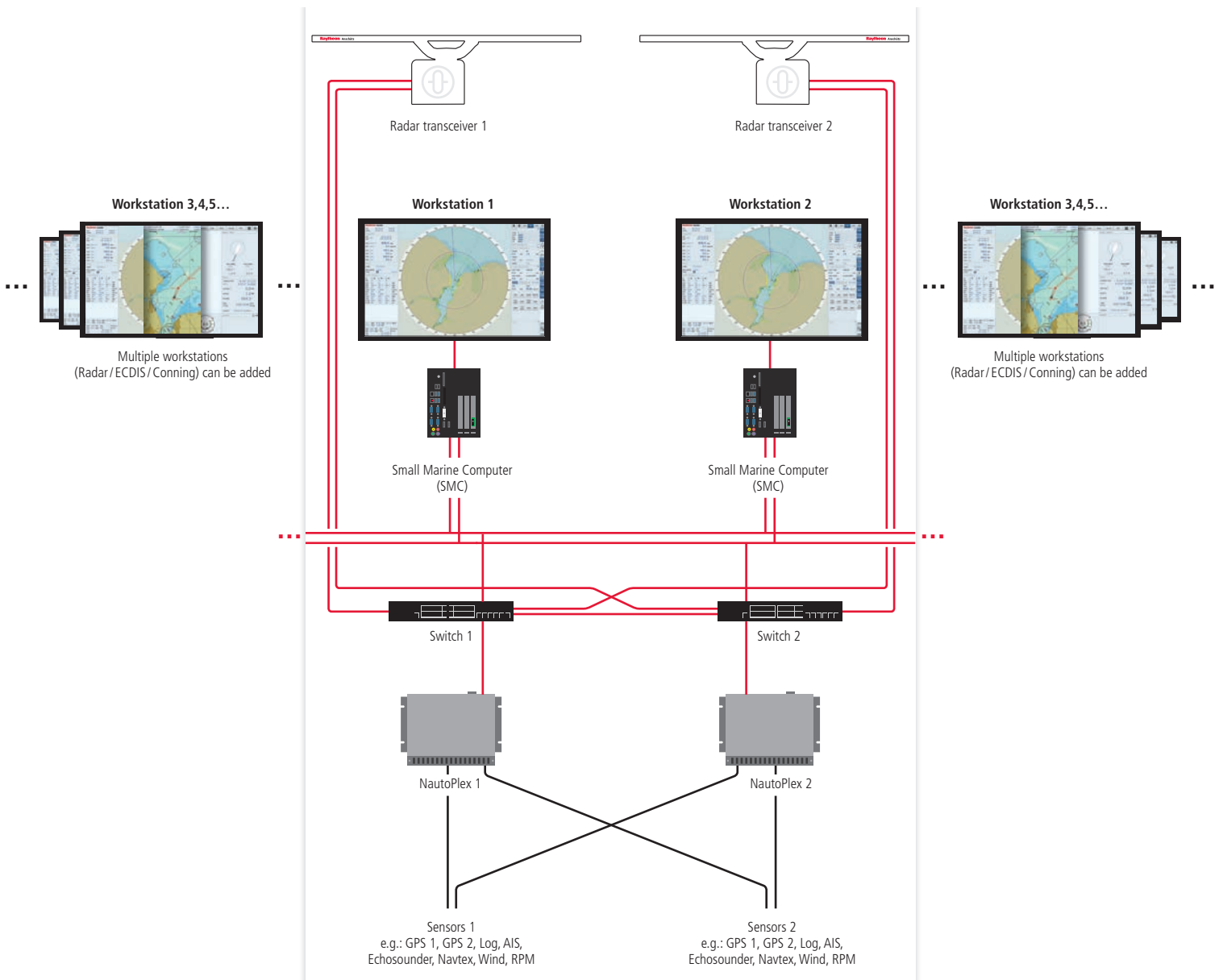



TECHNICAL DATA

Small Marine Computer

Our Small Marine Computer (SMC) is the standard for all Synopsis Workstations, making logistics fairly simple and thus shortening service time and cost. The SMC features a solid-state disk and passive cooling to increase reliability and lifetime. With its ultra-compact design and powerful processing capabilities, the SMC is ready for universal use on various ship types.

- Powerful Quadcore i7 microprocessor
- Fanless operation and solid-state SSD
- 1x DVI-I and 2x displayport video outputs
- 24V power supply

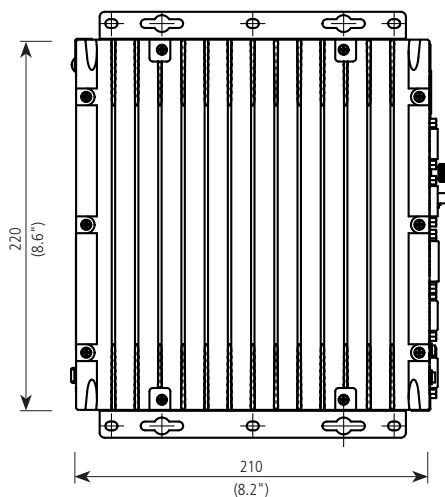
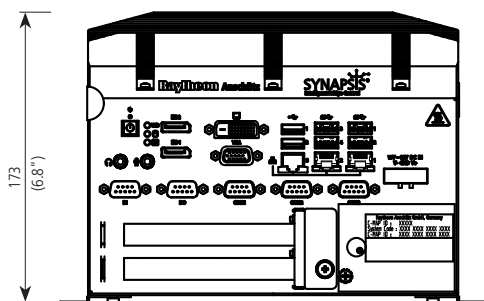

NautoPlex

The scalable NautoPlex serial to LAN converters collect all serial sensor data as well as status information and distribute data and information via LAN to the workstations. The result: reduced cabling effort and enhanced flexibility.

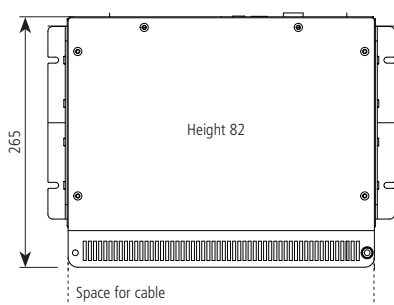

Ethernet switch

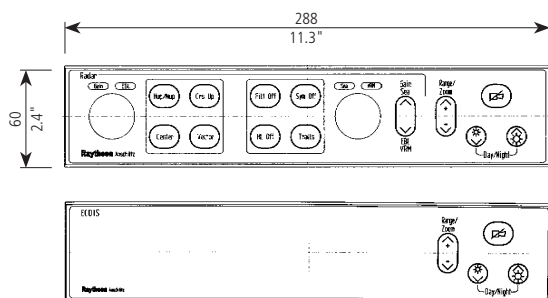
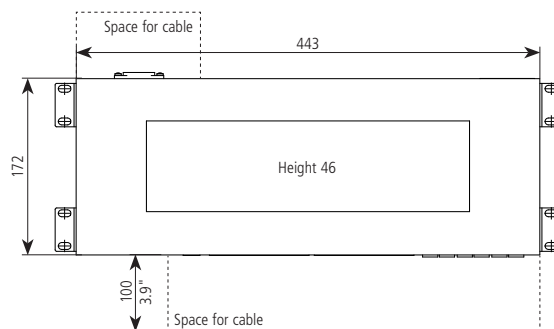

Radar operator panel / ECDIS operator panel

The operator panels enable simple operation of basic radar and ECDIS functions, among others range, dimming, color switch and alert acknowledgement. The radar operation panel also features physical rotary knobs and buttons for further radar functions and adjustments.

TECHNICAL DATA

Displays

The workstations feature 19", 26" or 27" TFT monitors with various options. Specific technical data is available on request. Furthermore new Synopsis Touch Panels (STP) are available for mounting into the consoles as a centralized display for alert management (INS, bridge level or as NAUT-OSV CAM-HMI) or other specific function (via Conning NX software modules). The STP is a 12" powerful panel PC with touch display, solid state disk and low-noise passive cooling.

- Resolution 27": 1920x1080 pixel 16:9
- Resolution 26": 1920x1200 pixel 16:10

Other sizes and resolutions on request.
 Technical data on request

Registered trademarks

Intel®, INTEL Corp.
 Microsoft Corporation

Synopsis Touch Panel

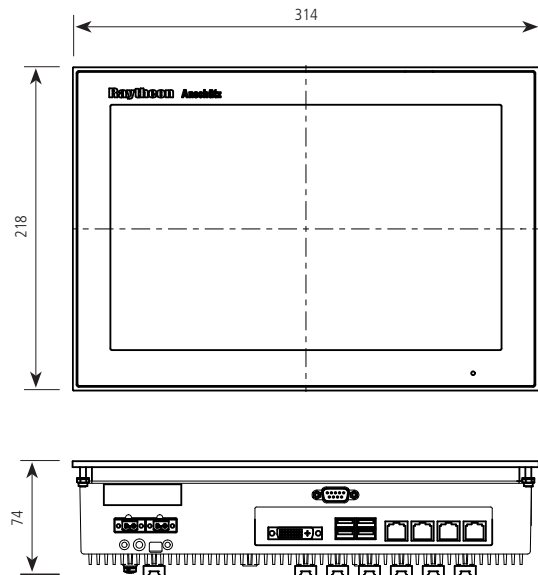

Consoles (deckstand, table top)

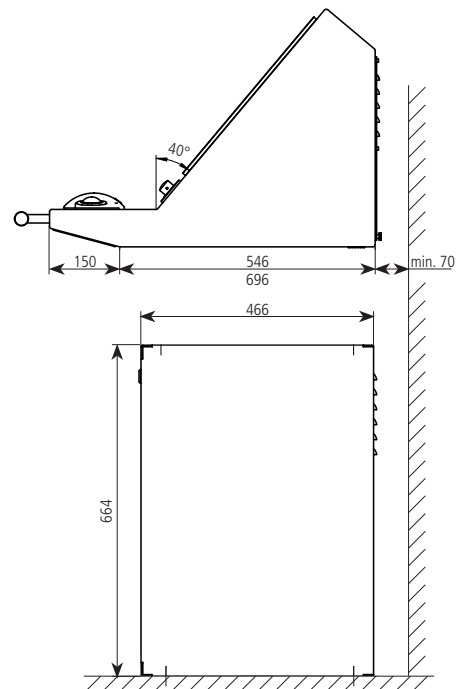
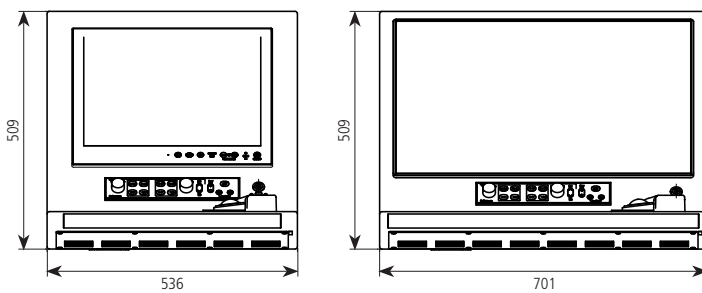

Example shows 19" and 26" consoles.
 Illustrations may vary.

Subject to change due to technical developments without notice.

© If not otherwise stated, all trademarks including Anschutz and  are registered by Raytheon Anschutz GmbH

All rights reserved · Printed in Germany · L&S 0818

Raytheon Anschutz GmbH

Headquarters
 D-24100 Kiel, Germany
 Tel +49(0)431-3019-0
 Fax +49(0)431-3019-291
 www.raytheon-anschutz.com